

WWZ

High efficiency HYBRID heat pumps with E.V.I compressor in two sections

RADWAN®

OSUSZANIE / WENTYLACJA / POMPY CIEPŁA

infolinia: +48 691 262 691

WWZ



The WWZ series of high efficiency hybrid heat pumps has been specifically designed for use with radiant floor heating systems or those applications where it is necessary to have maximum efficiency when heating.

They have been optimized on heating mode, are able to produce water up to 65°C. WWZ units are available in 2 or 4 pipe (SW6) versions. Both versions can produce domestic hot water, in the standard WWZ through the activation of an external 3-way-valve and in the SW6 version by means of a separate heat exchanger and hydraulic circuit for the domestic hot water. All models are supplied as standard with a reversing valve for defrost and cold water production in summer.

The main feature of WWZ units is that they have TWO heat exchangers on the source side (one air source, finned coil and the other a water plate type heat exchanger). The unit is primarily an air source heat pump but both source exchangers will work in series at low ambient conditions to maximise the operating efficiency of the unit. The COP will be superior to a standard air source heat pump.

OTHER VERSIONS

- **WWZ 2 pipes reversible standard.**
- **WWZ/SW6 4 pipes unit** able to produce hot and cold water at the same time on two independent hydraulic circuits.

ACCESSORIES

- **DSSE:** Electronic soft starter.
- **INSE:** RS485 interface bus card.
- **KAVG:** Rubber anti-vibration mountings.
- **KAVM:** Spring anti-vibration mountings.
- **MAML:** Refrigerant circuit pressure gauges.
- **PCRL:** Remote control panel.
- **BRCA:** Condensate discharge drip tray with antifreeze heater.
- **VTEE:** Electronic thermostatic valve.
- **VSLI:** Liquid line solenoid valve.
- **V2M0:** 2 way modulating valve to reduce source water consumption (4-20 mA; 0-10 V).
- **VECE:** High efficiency E.C. fans.

WWZ - WWZ/SW6 Models		14T	21	28	42
Heating capacity (EN14511) ⁽¹⁾	kW	13,9	19,6	30,9	41,4
Total input power (EN14511) ⁽¹⁾	kW	3,2	4,5	6,9	9,2
COP (EN14511) ⁽¹⁾	W/W	4,3	4,4	4,4	4,5
Heating capacity (EN14511) ⁽²⁾	kW	11,4	16,4	24,4	32,8
Total input power (EN14511) ⁽²⁾	kW	3,10	4,30	7,05	8,65
COP (EN14511) ⁽²⁾	W/W	3,7	3,8	3,5	3,8
Water flow integration ⁽²⁾	l/h	1100	1500	2000	3000
Heating capacity (EN14511) ⁽³⁾	kW	13,9	18,8	29,8	42,4
Total input power (EN14511) ⁽³⁾	kW	4,5	6,3	9,7	14,5
COP (EN14511) ⁽³⁾	W/W	3,1	3,0	3,0	2,9
Heating capacity (EN14511) ⁽⁴⁾	kW	11,6	15,7	24,9	32,8
Total input power (EN14511) ⁽⁴⁾	kW	4,3	6,0	9,2	12,1
COP (EN14511) ⁽⁴⁾	W/W	2,7	2,6	2,7	2,7
Water flow integration ⁽⁴⁾	l/h	1100	1500	2000	3000
Cooling capacity (EN14511) ⁽⁵⁾	kW	15,5	21,4	37,7	51,6
Total input power (EN14511) ⁽⁵⁾	kW	4,0	5,6	7,8	11,4
EER (EN14511) ⁽⁵⁾	W/W	3,9	3,8	4,8	4,5
Cooling capacity (EN14511) ⁽⁶⁾	kW	11,6	16,4	28,0	38,8
Total input power (EN14511) ⁽⁶⁾	kW	3,7	5,1	7,7	11,1
EER (EN14511) ⁽⁶⁾	W/W	3,1	3,2	3,2	3,2
Power supply	V/Ph/Hz	400/3+N/50	400/3+N/50	400/3/50	400/3/50
Max input current	A	12,0	15,8	22,6	30,6
Peak current	A	66,0	102,8	76,6	1131,6
Peak current standard unit with soft starter (optional)	A	39,7	62,3	44,6	64,6
Compressors	n° Scroll	1 E.V.I.	1 E.V.I.	2 E.V.I.	2 E.V.I.
Internal unit sound power level ⁽⁷⁾	dB (A)	54	60	60	60
Internal unit sound pressure level ⁽⁸⁾	dB (A)	46	52	52	52
Std external unit sound power level ⁽⁷⁾	dB (A)	66	66	68	70
Std external unit sound pressure level ⁽⁹⁾	dB (A)	38	38	40	42

OPERATION LIMITS

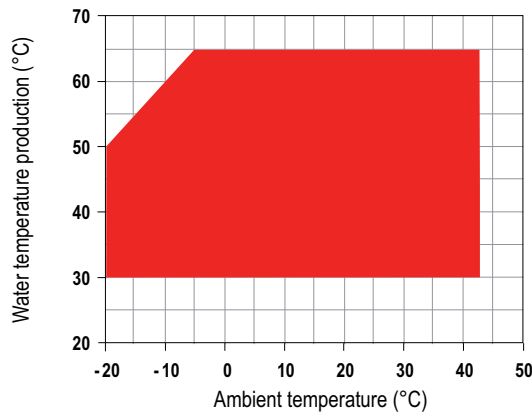

Performance refer to the following conditions:

- (1)Heating: Ambient temperature 7°C DB, 6°C WB, water temperature 30/35°C. Water Source Heat Exchanger INACTIVE.
- (2)Heating: Ambient temperature -7°C DB, 6°C WB, water temperature 30/35°C. Water Source Heat Exchanger ACTIVE. (Fluid temperature 10/7°C)
- (3)Heating: Ambient temperature 7°C DB, 6°C WB, water temperature 50/55°C. Water Source Heat Exchanger INACTIVE.
- (4)Heating: Ambient temperature -7°C DB, -8°C WB, water temperature 50/55°C. Water Source Heat Exchanger ACTIVE. (Fluid temperature 10/7°C)

- (5)Cooling: ambient temperature 35°C, water temperature 23/18°C. Water Source Heat Exchanger INACTIVE.
- (6)Cooling: ambient temperature 35°C, water temperature 12/7°C. Water Source Heat Exchanger INACTIVE.
- (7)Sound power level according to ISO 9614.
- (8)Sound pressure level at 1 mt from the unit in free field conditions direction factor Q=2, calculated in accordance with ISO 9614.
- (9)Sound pressure level at 10 mt from the unit in free field conditions direction factor Q=2, in accordance with ISO 9614.

WWZ - WWZ/SW6 Models		52	72	82	92
Heating capacity (EN14511) ⁽¹⁾	kW	52,0	74,7	89,4	106,3
Total input power (EN14511) ⁽¹⁾	kW	11,8	18,1	22,0	26,2
COP (EN14511) ⁽¹⁾	W/W	4,4	4,1	4,1	4,1
Heating capacity (EN14511) ⁽²⁾	kW	43,5	59,0	75,0	86,3
Total input power (EN14511) ⁽²⁾	kW	11,2	17,0	21,2	25,0
COP (EN14511) ⁽²⁾	W/W	3,9	3,5	3,5	3,5
Water flow integration ⁽²⁾	l/h	3650	5350	6250	7500
Heating capacity (EN14511) ⁽³⁾	kW	53,7	71,9	92,3	106,2
Total input power (EN14511) ⁽³⁾	kW	17,8	25,0	31,5	35,3
COP (EN14511) ⁽³⁾	W/W	3,0	2,9	2,9	3,0
Heating capacity (EN14511) ⁽⁴⁾	kW	44,6	59,0	77,2	86,4
Total input power (EN14511) ⁽⁴⁾	kW	16,5	23,5	29,7	33,2
COP (EN14511) ⁽⁴⁾	W/W	2,7	2,5	2,6	2,6
Water flow integration ⁽⁴⁾	l/h	3650	5350	6250	7500
Cooling capacity (EN14511) ⁽⁵⁾	kW	57,8	84,4	93,2	117,0
Total input power (EN14511) ⁽⁵⁾	kW	15,2	23,6	27,0	33,2
EER (EN14511) ⁽⁵⁾	W/W	3,8	3,6	3,5	3,5
Cooling capacity (EN14511) ⁽⁶⁾	kW	42,4	61,8	75,0	90,2
Total input power (EN14511) ⁽⁶⁾	kW	13,3	21,4	26,4	31,1
EER (EN14511) ⁽⁶⁾	W/W	3,2	2,9	2,8	2,9
Power supply	V/Ph/Hz	400/3/50	400/3/50	400/3/50	400/3/50
Max input current	A	39,2	55,0	62,0	76,9
Peak current	A	119,9	158,8	202,3	242,9
Peak current standard unit with soft starter (optional)	A	80,2	106,9	135,5	164,2
Compressors	n° Scroll	2 E.V.I.	2 E.V.I.	2 E.V.I.	2 E.V.I.
Internal unit sound power level ⁽⁷⁾	dB (A)	61	62	63	63
Internal unit sound pressure level ⁽⁸⁾	dB (A)	53	54	55	55
Std external unit sound power level ⁽⁷⁾	dB (A)	70	71	71	72
Std external unit sound pressure level ⁽⁹⁾	dB (A)	42	43	43	44

OPERATION LIMITS

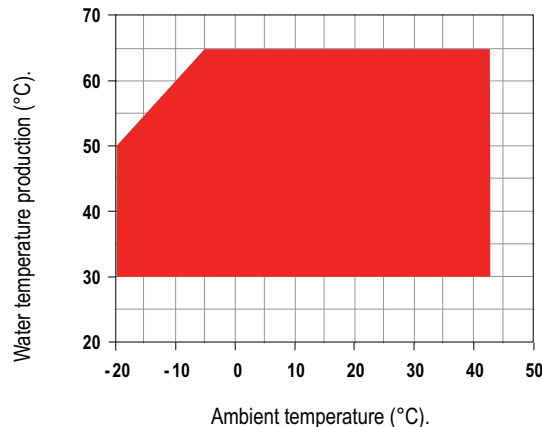

Performance refer to the following conditions:

- (1)Heating: Ambient temperature 7°C DB, 6°C WB, water temperature 30/35°C. Water Source Heat Exchanger INACTIVE.
- (2)Heating: Ambient temperature -7°C DB, 6°C WB, water temperature 30/35°C. Water Source Heat Exchanger ACTIVE. (Fluid temperature 10/7°C)
- (3)Heating: Ambient temperature -7°C DB, 6°C WB, water temperature 50/55°C. Water Source Heat Exchanger INACTIVE.
- (4)Heating: Ambient temperature -7°C DB, -8°C WB, water temperature 50/55°C. Water Source Heat Exchanger ACTIVE. (Fluid temperature 10/7°C)

- (5)Cooling: ambient temperature 35°C, water temperature 23/18°C. Water Source Heat Exchanger INACTIVE.
- (6)Cooling: ambient temperature 35°C, water temperature 12/7°C. Water Source Heat Exchanger INACTIVE.
- (7)Sound power level according to ISO 9614.
- (8)Sound pressure level at 1 mt from the unit in free field conditions direction factor Q=2, calculated in accordance with ISO 9614.
- (9)Sound pressure level at 10 mt from the unit in free field conditions direction factor Q=2, in accordance with ISO 9614.

FRAME

All WWZ units are made from hot-galvanised sheet steel, painted with polyurethane powder enamel and stoved at 180°C to provide maximum protection against corrosion. The frame is self-supporting with removable panels. All screws and rivets used are made from stainless steel. The standard colour of the units is RAL 9018.

REFRIGERANT CIRCUIT

The refrigerant utilised is R407C. The refrigerant circuit is assembled using internationally recognised brand name components with all brazing and welding being performed in accordance with ISO 97/23. The refrigerant circuit includes: sight glass, filter drier, two thermal expansion valves (one for cooling mode, one for heating mode) with external equalizer, 4 way reversing valve, check valves, liquid receiver, Schrader valves for maintenance and control, pressure safety device (for compliance with PED regulations). The circuit also includes an AISI316 stainless steel heat exchanger that is used as an economizer plus an additional expansion valve for refrigerant vapour injection.

COMPRESSOR

Heat pumps utilise scroll compressors that are equipped with E.V.I. technology, a versatile method of improving system capacity and efficiency. EVI stands for "Economised Vapour Injection." The technology involves injecting refrigerant vapour into the middle of the compression process, a procedure that significantly boosts capacity and efficiency. Each scroll compressor used in these units is similar to a two-stage compressor with built-in interstage cooling. The process begins when a portion of the condenser liquid is entrained and expanded through an expansion valve. The low temperature liquid/gas mixture produced is injected into a heat exchanger that operates as a sub cooler. Any liquid is evaporated and the vapour produced is superheated. The superheated vapour is then injected into an intermediate port in the scroll compressor. This cold vapour reduces the temperature of the compressed gas thus enabling the compressor to raise the pressure to levels (and temperatures) beyond that possible with a single stage scroll.

The additional sub cooling of the main volume of liquid refrigerant increases the evaporator capacity. This compressor technology generates a larger pressure ratio between condensing and evaporating pressures, with significant performance improvement. The compressors are connected in tandem and are all supplied with a crankcase heater and thermal overload protection by a klixon embedded in the motor winding. They are mounted in a separate enclosure in order to be separated from the air stream thus enabling them to be maintained even if the unit is operating. Access to this enclosure is via the front panel of the unit. The crankcase heater is always powered when the compressor is in stand-by.

AIR SOURCE HEAT EXCHANGER

The air source heat exchanger is made from 3/8" copper pipes and 0,1mm thick aluminium fins with the tubes being mechanically expanded into the aluminium fins in order to maximise heat transfer. Furthermore, the design guarantees a low air side pressure drop thus enabling the use of low rotation speed (and hence low noise) fans. The exchangers can be protected by a metallic filter that is available as an accessory.

WATER SOURCE HEAT EXCHANGER

The water source heat exchanger is a braze welded, plate type heat exchanger, manufactured from AISI 316 stainless steel. Utilisation of this type of exchanger results in a massive reduction of the refrigerant charge of the unit compared to a traditional shell-in-tube evaporator. A further advantage is a reduction in the overall dimensions of the unit. The exchangers are factory insulated with flexible close cell material and can be fitted with an antifreeze heater (accessory). Each exchanger is fitted with a temperature sensor on the discharge water side for antifreeze protection.

FANS

The fans are direct drive axial type with aluminium aerofoil blades, are statically and dynamically balanced and are supplied complete with a safety fan guard complying with the requirements of EN 60335. They are fixed to the unit frame via rubber anti-vibration mountings. The electric motors are

6 pole type rotating at approximately 900 rpm. As standard, all units are fitted with a pressure operated fan speed controller. The motors are fitted with integrated thermal overload protection and have a moisture protection rating of IP 54.

USER HEAT EXCHANGER

The user heat exchanger is a braze welded, plate type heat exchanger, manufactured from AISI 316 stainless steel. Utilisation of this type of exchanger results in a massive reduction of the refrigerant charge of the unit compared to a traditional shell-in-tube type. A further advantage is a reduction in the overall dimensions of the unit. The exchangers are factory insulated with flexible close cell material. Each exchanger is fitted with a temperature sensor on the discharge water side for antifreeze protection.

ELECTRIC ENCLOSURE

The enclosure is manufactured in order to comply with the requirements of the electromagnetic compatibility standards CEE 73/23 and 89/336. Access to the enclosure is achieved by removing the front panel of the unit. The following components are supplied as standard on all units: main switch, a sequence relay that disables the power supply in the event that the phase sequence is incorrect (scroll compressors can be damaged if they rotate in the wrong direction), thermal overloads (protection of pumps and fans), compressor fuses, control circuit automatic breakers, compressor contactors, fan contactors and pump contactors. The terminal board has volt free contacts for remote ON-OFF, Summer/Winter change over and general alarm.

MICROPROCESSORS

All WWZ units are supplied as standard with microprocessor controls. The microprocessor controls the following functions: control of the water temperature, antifreeze protection, compressor timing, compressor automatic starting sequence (For multiple compressors), alarm reset. The control panel is supplied with display showing all operational icons. The microprocessor is set for automatic defrost (when operating in severe ambient conditions) and for summer/winter change over. The control also

WWZ

manages the anti-legionella program, the integration with other heating sources (electric heaters, boilers, solar panels etc), the operation of a three port modulating valve (for diverting to DHW or heating) and both the heating circuit pump and the domestic hot water circuit pump. If required (available as an option), the microprocessor can be configured in order for it to connect to a site BMS system thus enabling remote

control and management. The Hidros technical department can discuss and evaluate, in conjunction with the customer, solutions using MODBUS protocols.

CONTROL AND PROTECTION DEVICES

All units are supplied with the following control and protection devices: Return user water temperature sensor, antifreeze protection sensor installed on the user out-

let water temperature, return and supply, high pressure switch with manual reset, low pressure switch with automatic reset, high pressure safety valve, compressor thermal overload protection, fans thermal overload protection, pressure transducer (used to optimize the defrost cycle and the fan speed depending on the ambient conditions), flow switch.

PRINCIPLE OF OPERATION

The use of the water source heat exchanger only in harsh environmental conditions only, allows the unit to operate with the air source for most of the time, integrating the power missing with the water but also ensuring an extreme reduction of water consumption.

The applications of hybrid heat pumps are absolutely interesting in those cases where supplementary sources of different nature are available at lower cost. The integrated power from the water heat exchanger to water is about 30% of the power unit, in this way there are not needed high cost of adduction.

Some water sources used:

- Integrative source through the use of well water
- Integrative source through the use of geothermal
- Integrative source through the use of wastewater
- Integrative source through the use of solar panels.

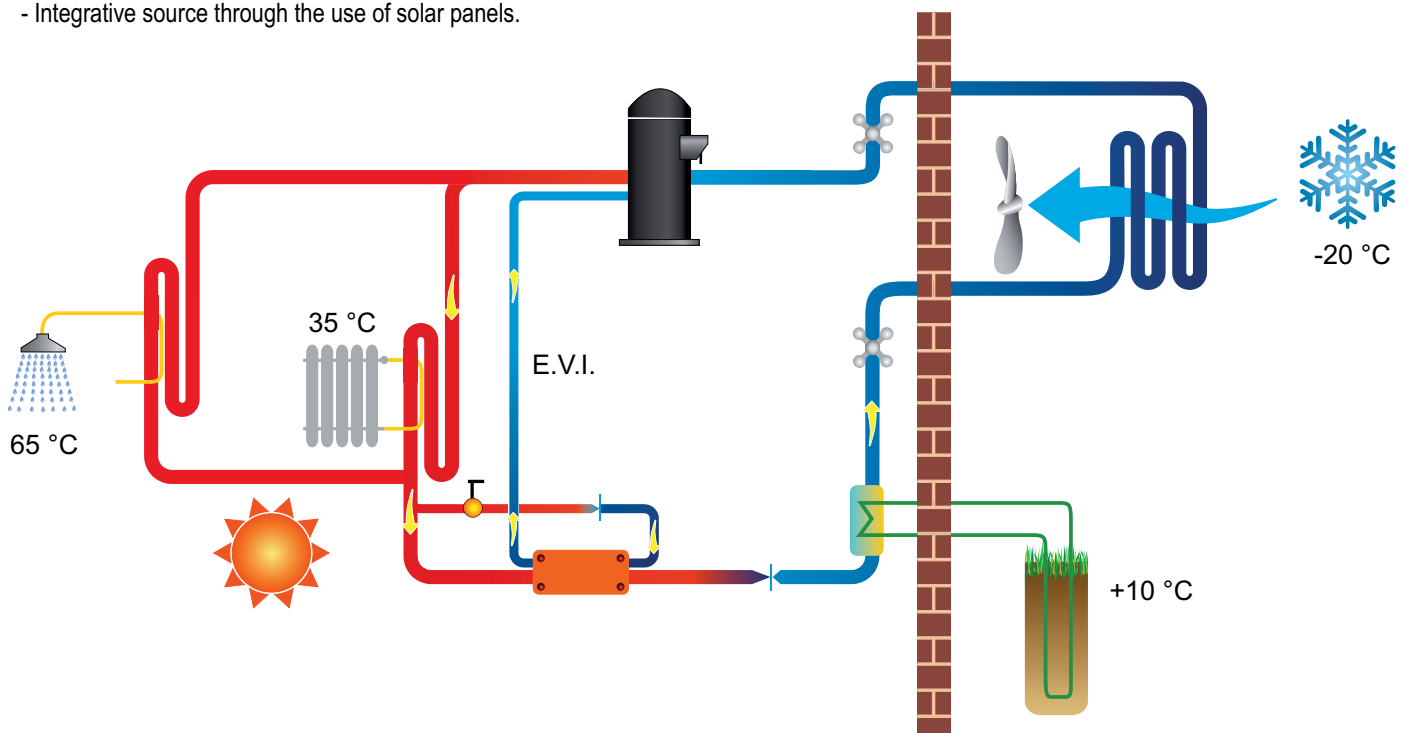

Refrigerant circuit layout of a WWZ/SW6 hybrid heat pump, supplied with domestic hot water heat exchanger and additional ground source heat exchanger to enhance the efficiency of the unit in case of severe ambient condition and to improve the seasonal C.O.P.

PERFORMANCE COMPARISON C.O.P. IN HYBRID WWZ UNITS AND IN WZT UNIT.

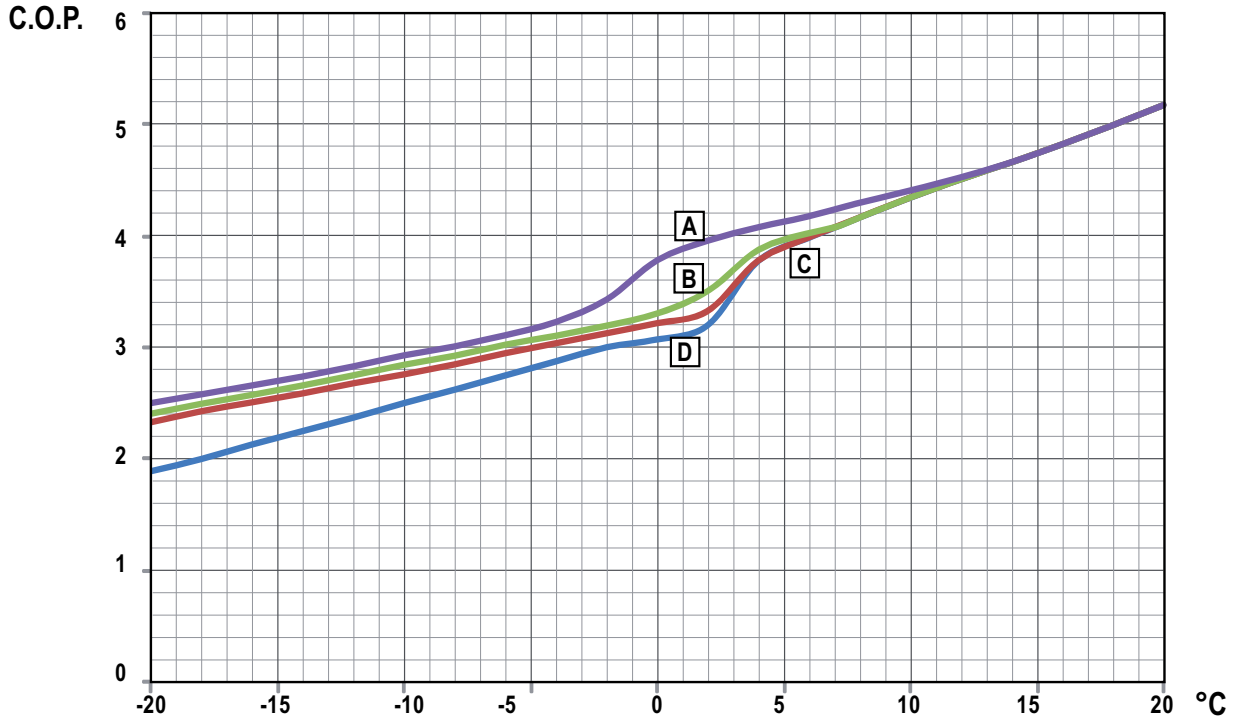

The graph shows the evolution of WWZ units C.O.P. (curves A, B, C) at different external temperatures (with user water produced at 35 °C), compared to a unit of equal power series WZT (curve D).
 The curves A, B, C refer to different conditions of the water source and, in particular:
 Curve A: 10/7 °C, Curve B: 3/0 °C, Curve C: 0/-3 °C.
 As can be seen the performance difference is always increased with decreasing outdoor temperature to fit to the maximum value in correspondence of -20 °C outside.

Connections diagrams

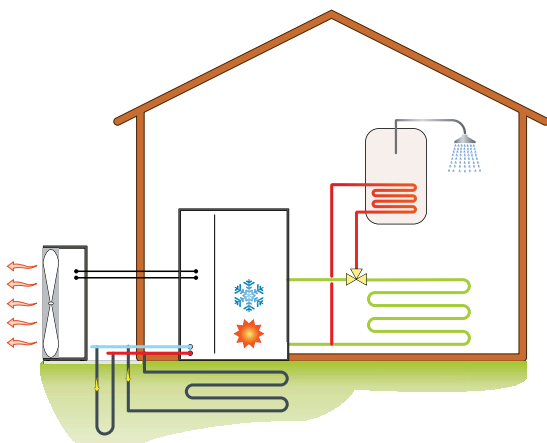

WWZ 2 PIPES VERSION.

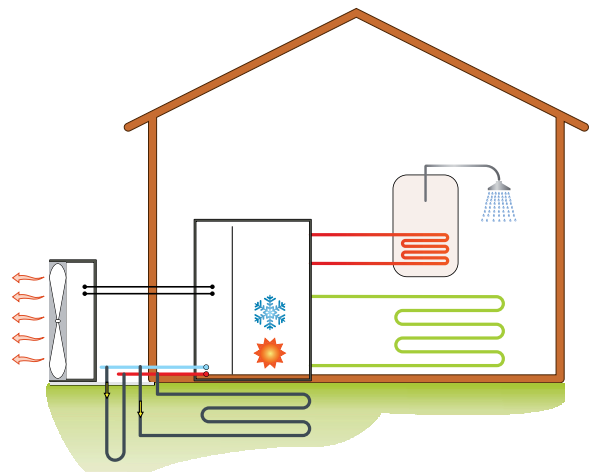

WWZ/SW6 4 PIPES VERSION.

WWZ - WWZ/SW6 Versions	Code	14T	21	28	42
Main switch		●	●	●	●
Microprocessor control		●	●	●	●
Remote ON/OFF digital input		●	●	●	●
Summer/Winter digital input		●	●	●	●
Condensate tray with anti-freeze heater (outdoor section)	BRCA	●	●	●	●
LS Low noise version	LS00	●	●	●	●
Electronic soft starter	DSSE	○	○	○	○
Rubber anti-vibration mountings	KAVG	○	○	○	○
Spring anti-vibration mountings.	KAVM	○	○	○	○
Refrigerant circuit pressure gauges	MAML	○	○	○	○
Liquid line solenoid valve	VSLI	○	○	○	○
Remote control panel	PCRL	○	○	○	○
RS485 interface bus card	INSE	○	○	○	○
Electronic thermostatic valve	VTEE	○	○	○	○
2 way modulating to control source water consumption	V2M0	○	○	○	○
High efficiency E.C. fans	VECE	○	○	○	○

● Standard, ○ Optional, – Not Available.

INDOOR UNITS

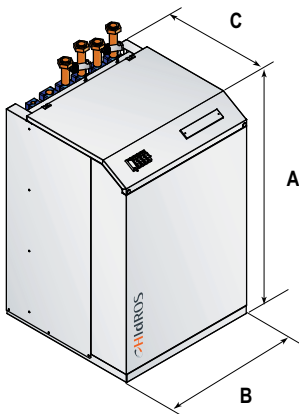

WWZ 14 ÷ 21

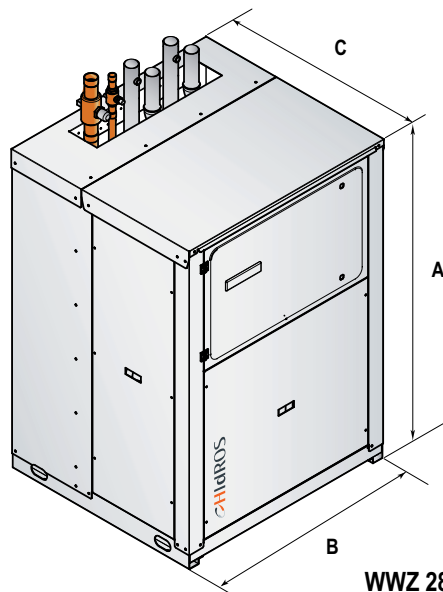

WWZ 28 ÷ 92

Mod.	A (mm)	B (mm)	C (mm)	Kg
14T	1255	600	600	130
21	1255	600	600	150
28	1270	850	765	165
42	1566	1101	1005	390
52	1566	1101	1005	460
72	1566	1101	1005	480
82	1566	1101	1005	490
92	1566	1101	1005	580

WWZ - WWZ/SW6 Versions	Code	52	72	82	92
Main switch		●	●	●	●
Microprocessor control		●	●	●	●
Remote ON/OFF digital input		●	●	●	●
Summer/Winter digital input		●	●	●	●
Condensate tray with anti-freeze heater (outdoor section)	BRCA	●	●	●	●
LS Low noise version	LS00	●	●	●	●
Electronic soft starter	DSSE	○	○	○	○
Rubber anti-vibration mountings	KAVG	○	○	○	○
Spring anti-vibration mountings.	KAVM	○	○	○	○
Refrigerant circuit pressure gauges	MAML	○	○	○	○
Liquid line solenoid valve	VSLI	○	○	○	○
Remote control panel	PCRL	○	○	○	○
RS485 interface bus card	INSE	○	○	○	○
Electronic thermostatic valve	VTEE	○	○	○	○
2 way modulating to control source water consumption	V2M0	○	○	○	○
High efficiency E.C. fans	VECE	○	○	○	○

● Standard, ○ Optional, – Not Available.

OUTDOOR UNITS

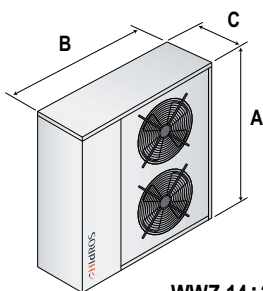

WWZ 14÷21

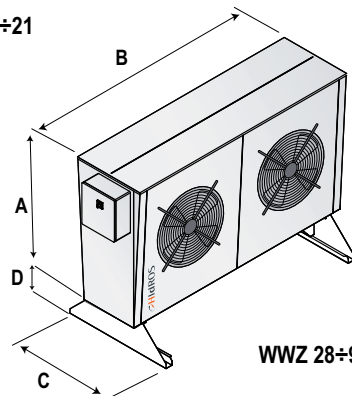

WWZ 28÷92

Mod.	A (mm)	B (mm)	C (mm)	D (mm)	Kg
14T	1323	1245	423	-	56
21	1424	1510	473	-	91
28	1035	3065	800	350	112
42	1035	3065	800	350	112
52	1615	2900	1200	350	230
72	1615	4110	1200	350	378
82	1615	4110	1200	350	470
92	1615	5300	1200	350	517