

## WZT

### High Efficiency Air to Water Split System Heat Pumps With E.V.I. Compressors



C.O.P. ≥ 4,1



The WZT series of high efficiency heat pumps has been specifically designed for use with radiant floor heating systems or those applications where it is necessary to have maximum efficiency when heating.

They have been optimized on heating mode, are able to produce water up to 65°C and can operate down to -20°C ambient temperature. These units have been designed for those applications where the noise level has to be as low as possible. They are therefore in a split configuration with the compressor(s) being located in the indoor section.

The outdoor source exchanger can be located in a position that is not noise critical. Connection between indoor and outdoor sections is by refrigerant lines.

WZT units are available in 2 or 4 pipe (SW6) versions.

Both versions can produce domestic hot water, in the standard WZT through the activation of an external 3-way-valve and in the SW6 version by means of a separate heat exchanger and hydraulic circuit for the domestic hot water.

All models are supplied as standard with a reversing valve for defrost and cold water production in summer.

### OTHER VERSIONS

- **WZT 2 pipes reversible standard.**
- **WZT/SW6 4 pipes unit** able to produce hot and cold water at the same time on two independent hydraulic circuits.

### ACCESSORIES

- **BRCA:** Condensate discharge drip tray with antifreeze heater.
- **DSSE:** Electronic soft starter.
- **INSE:** Serial interface card RS 485.
- **KAVG:** Rubber anti-vibration mountings.
- **RAEV:** Evaporator antifreeze heater.
- **LS00:** Low noise version.
- **MAML:** Refrigerant circuit pressure gauges.
- **PCRL:** Remote control panel.
- **VTEE:** Electronic thermostatic valve

WZT - WZT/SW6 Models		06	08	10M	10T	14M	14T	21
Heating capacity (EN14511) <sup>(1)</sup>	kW	6,7	8,8	9,6	9,6	13,9	13,9	19,6
Total input power (EN14511) <sup>(1)</sup>	kW	1,6	2,1	2,3	2,3	3,3	3,2	4,5
COP (EN14511) <sup>(1)</sup>	W/W	4,1	4,2	4,2	4,2	4,2	4,3	4,4
Heating capacity (EN14511) <sup>(2)</sup>	kW	4,5	5,9	6,9	6,8	9,9	9,9	14,3
Total input power (EN14511) <sup>(2)</sup>	kW	1,5	1,9	2,1	2,0	3,1	3,0	4,1
COP (EN14511) <sup>(2)</sup>	W/W	3,0	3,1	3,3	3,4	3,2	3,3	3,5
Cooling capacity (EN14511) <sup>(3)</sup>	kW	6,9	9,6	11,3	11,3	15,4	15,5	21,4
Total input power (EN14511) <sup>(3)</sup>	kW	2,1	2,5	3,0	2,9	4,1	4,0	5,6
EER (EN14511) <sup>(3)</sup>	W/W	3,3	3,8	3,8	3,9	3,8	3,9	3,8
Cooling capacity (EN14511) <sup>(4)</sup>	kW	4,9	7,0	8,5	8,7	11,5	11,6	16,4
Total input power (EN14511) <sup>(4)</sup>	kW	1,8	2,2	2,6	2,5	3,8	3,7	5,1
EER (EN14511) <sup>(4)</sup>	W/W	2,7	3,2	3,3	3,5	3,0	3,1	3,2
Power supply	V/Ph/Hz	230/1/50	230/1/50	230/1/50	400/3+N/50	230/1/50	400/3+N/50	400/3+N/50
Max input current	A	15,1	19,5	21,0	7,0	32,0	12,0	15,8
Peak current	A	58,6	77,0	98,0	41,0	162,0	66,0	102,8
Peak current std unit with soft starter (optional)	A	36,6	50,6	58,8	24,6	97,3	39,7	62,3
Compressors	n° scroll	1 HP	1 HP	1 E.V.I.	1 E.V.I.	1 E.V.I.	1 E.V.I.	1 E.V.I.
Internal unit sound power level <sup>(5)</sup>	dB (A)	51	52	52	52	54	54	60
Internal unit sound pressure level <sup>(6)</sup>	dB (A)	43	44	44	44	46	46	52
Std external unit sound power level <sup>(5)</sup>	dB (A)	63	63	63	63	66	66	66
Std external unit sound pressure level <sup>(7)</sup>	dB (A)	35	35	35	35	38	38	38

WZT - WZT/SW6 Models		28	42	52	72	82	92
Heating capacity (EN14511) <sup>(1)</sup>	kW	30,9	41,4	52,0	74,7	89,4	106,3
Total input power (EN14511) <sup>(1)</sup>	kW	6,9	9,2	11,8	18,1	22,0	26,2
COP (EN14511) <sup>(1)</sup>	W/W	4,4	4,5	4,4	4,1	4,1	4,1
Heating capacity (EN14511) <sup>(2)</sup>	kW	20,0	27,2	37,3	50,4	64,7	74,6
Total input power (EN14511) <sup>(2)</sup>	kW	6,5	8,8	10,8	16,4	20,4	24,0
COP (EN14511) <sup>(2)</sup>	W/W	3,0	3,0	3,5	3,0	3,2	3,1
Cooling capacity (EN14511) <sup>(3)</sup>	kW	37,7	51,6	57,8	84,4	93,2	117,0
Total input power (EN14511) <sup>(3)</sup>	kW	7,8	11,4	15,2	23,6	27,0	33,2
EER (EN14511) <sup>(3)</sup>	W/W	4,8	4,5	3,8	3,6	3,5	3,5
Cooling capacity (EN14511) <sup>(4)</sup>	kW	28,0	38,8	42,4	61,8	75,0	90,2
Total input power (EN14511) <sup>(4)</sup>	kW	7,7	11,1	13,3	21,4	26,4	31,1
EER (EN14511) <sup>(4)</sup>	W/W	3,2	3,2	3,2	2,9	2,8	2,9
Power supply	V/Ph/Hz	400/3/50	400/3/50	400/3/50	400/3/50	400/3/50	400/3/50
Max input current	A	22,6	30,6	39,2	55,0	62,0	76,9
Peak current	A	76,6	1131,6	119,9	158,8	202,3	242,9
Peak current std unit with soft starter (optional)	A	44,6	64,6	80,2	106,9	135,5	164,2
Compressors	n° scroll	2 E.V.I.	2 E.V.I.	2 E.V.I.	2 E.V.I.	2 E.V.I.	2 E.V.I.
Internal unit sound power level <sup>(5)</sup>	dB (A)	60	60	61	62	63	63
Internal unit sound pressure level <sup>(6)</sup>	dB (A)	52	52	53	54	55	55
Std external unit sound power level <sup>(5)</sup>	dB (A)	68	70	70	71	71	72
Std external unit sound pressure level <sup>(7)</sup>	dB (A)	40	42	42	43	43	44

Performance refer to the following conditions:

- (1)Heating: Ambient temperature 7°C DB, 6°C WB, water temperature 30/35°C.
- (2)Heating: Ambient temperature -7°C DB, -8°C WB, water temperature 30/35°C.
- (3)Cooling: ambient temperature 35°C, water temperature 23/18°C.
- (4)Cooling: ambient temperature 35°C, water temperature 12/7°C.

(5)Sound power level according to ISO 9614..

(6)Sound pressure level at 1 mt from the unit in free field conditions direction factor Q=2, calculated in accordance with ISO 9614.

(7) Sound pressure level at 10 mt from the unit in free field conditions direction factor Q=2, in accordance with ISO 9614.

## WZT

### FRAME

All WZT units are made from hot-galvanised sheet steel, painted with polyurethane powder enamel and stoved at 180°C to provide maximum protection against corrosion. The frame is self-supporting with removable panels. All screws and rivets used are made from stainless steel. The standard colour of the units is RAL 7035.

### REFRIGERANT CIRCUIT

The refrigerant utilised is R407C. The refrigerant circuit is assembled using internationally recognised brand name components with all brazing and welding being performed in accordance with ISO 97/23. The refrigerant circuit includes: sight glass, filter drier, two thermal expansion valves (one for cooling mode, one for heating mode) with external equalizer, 4 way reversing valve, check valves, liquid receiver, Schrader valves for maintenance and control, pressure safety device (for compliance with PED regulations). From model size 10 upwards the circuit also includes an AISI316 stainless steel heat exchanger that is used as an economizer plus an additional expansion valve for refrigerant vapour injection.

### COMPRESSORS

HIDROS WZT heat pumps from model size 10 upwards utilise scroll compressors that are equipped with E.V.I. technology, a versatile method of improving system capacity and efficiency. EVI stands for "Economised Vapour Injection." The technology involves injecting refrigerant vapour into the middle of the compression process, a procedure that significantly boosts capacity and efficiency. Each scroll compressor used in these units is similar to a two-stage compressor with built-in inter-stage cooling. The process begins when a portion of the condenser liquid is extracted and expanded through an expansion valve. The low temperature liquid/gas mixture produced is injected into a heat exchanger that operates as a sub cooler. Any liquid is evaporated and the vapour produced is superheated.

The superheated vapour is then injected into an intermediate port in the scroll compressor. This cold vapour reduces the temperature of the compressed gas thus enabling the compressor to raise the pressure to levels (and temperatures) beyond that possible with a single stage scroll. The

additional sub cooling of the main volume of liquid refrigerant increases the evaporator capacity. This compressor technology generates a larger pressure ratio between condensing and evaporating pressures, with significant performance improvement. From size 28 upwards, the compressors are connected in tandem. The compressors are all supplied with a crankcase heater and thermal overload protection by a klixon embedded in the motor winding. They are mounted in a separate enclosure in order to be separated from the air stream thus enabling them to be maintained even if the unit is operating. Access to this enclosure is by the front panel of the unit. The crankcase heater is always powered when the compressor is in stand-by.

### SOURCE HEAT EXCHANGER

The source heat exchanger is made from 3/8" copper pipes and 0.1mm thick aluminium fins with the tubes being mechanically expanded into the aluminium fins in order to maximise heat transfer. Furthermore, the design guarantees a low air side pressure drop thus enabling the use of low rotation speed (and hence low noise) fans. The exchangers can be protected by a metallic filter that is available as an accessory. Incorporated into the assembly are the fans that are direct drive axial type with aluminium aerofoil blades, statically and dynamically balanced and supplied complete with a safety fan guard complying with the requirements of EN 60335.

They are fixed to the unit frame via rubber anti-vibration mountings. As standard, all units are fitted with a pressure operated fan speed controller.

The electric motors are 6 pole type rotating at approximately 900 rpm. The motors are fitted with integrated thermal overload protection and have a moisture protection rating of IP 54.

### USER HEAT EXCHANGERS

The user heat exchanger is a braze welded, plate type heat exchanger, manufactured from AISI 316 stainless steel. Utilisation of this type of exchanger results in a massive reduction of the refrigerant charge of the unit compared to a traditional shell-in-tube type. A further advantage is a reduction in the overall dimensions of the unit.

The exchangers are factory insulated with flexible close cell material and can be fitted with an antifreeze heater (accessory). Each exchanger is fitted with a temperature sensor on the discharge water side for anti-freeze protection.

### MICROPROCESSORS

All WZT units are supplied as standard with microprocessor controls. The microprocessor controls the following functions: control of the water temperature, antifreeze protection, compressor timing, compressor automatic starting sequence (For multiple compressors), alarm reset. The control panel is supplied with display showing all operational icons. The microprocessor is set for automatic defrost (when operating in severe ambient conditions) and for summer/ winter change over. The control also manages the anti-legionella program, the integration with other heating sources (electric heaters, boilers, solar panels etc), the operation of a three port modulating valve (for diverting to DHW or heating) and both the heating circuit pump and the domestic hot water circuit pump. If required (available as an option), the microprocessor can be configured in order for it to connect to a site BMS system thus enabling remote control and management. The Hidros technical department can discuss and evaluate, in conjunction with the customer, solutions using MODBUS protocols.

### ELECTRIC ENCLOSURE

The enclosure is manufactured in order to comply with the requirements of the electromagnetic compatibility standards CEE 73/23 and 89/336. Access to the enclosure is achieved by removing the front panel of the unit. The following components are supplied as standard on all units: main switch, thermal overloads (protection of pumps and fans), compressor fuses, control circuit automatic breakers, compressor contactors, fan contactors and pump contactors.

The terminal board has volt free contacts for remote ON-OFF, Summer/Winter change over and general alarm. For all three phase units, a sequence relay that disables the power supply in the event that the phase sequence is incorrect (scroll compressors can be damaged if they rotate in the wrong direction), is fitted as standard.

# WZT

## CONTROL AND PROTECTION DEVICES

All units are supplied with the following control and protection devices: Return user water temperature sensor, antifreeze protection sensor installed on the user outlet water temperature, return and supply, high pressure switch with manual reset, low pressure switch with automatic reset, high pressure safety valve, compressor thermal overload protection, fans thermal overload protection, pressure transducer (used to optimize the defrost cycle and the fan speed depending on the ambient conditions), flow switch.

## OTHER VERSIONS

### WZT/SW6 UNIT WITH INDEPENDENT DOMESTIC HOT WATER PRODUCTION

This version is fitted with an additional heat exchanger, used as condenser, to produce domestic hot water irrespective of the operation mode of the unit. The activation of the additional heat exchanger is performed automatically by the microprocessor control when the domestic hot water temperature, measured by the sensor, is lower than the required set point. If, during the summer months, the unit is operating on cooling, this version can produce hot and

cold water simultaneously. This version is equipped with return and supply domestic hot water sensors and an advanced control panel with specific software for management of the system priorities.

## VERSIONS

### WZT/LS LOW NOISE VERSION

This version has acoustic insulation applied to the unit (both the compressor and its enclosure) in the form of compressor jackets and insulating material made with high density media coated with a heavy bitumen layer.

## OPERATION LIMITS

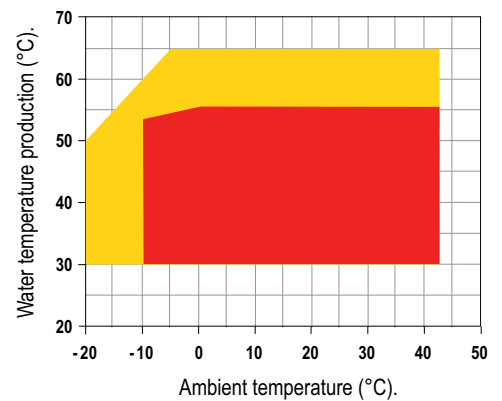

Mod. WZT 10 ÷ 92

Mod. WZT 06 ÷ 08

## Connections diagrams WZT WZT/SW6

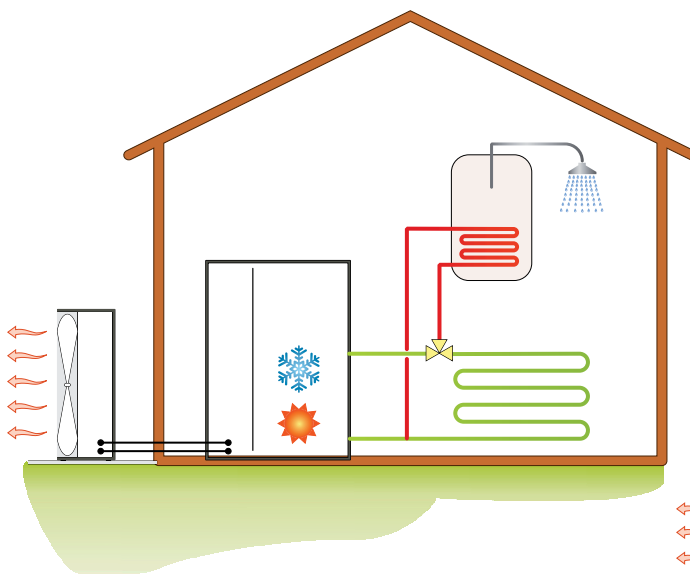

WZT 2 PIPES VERSION.

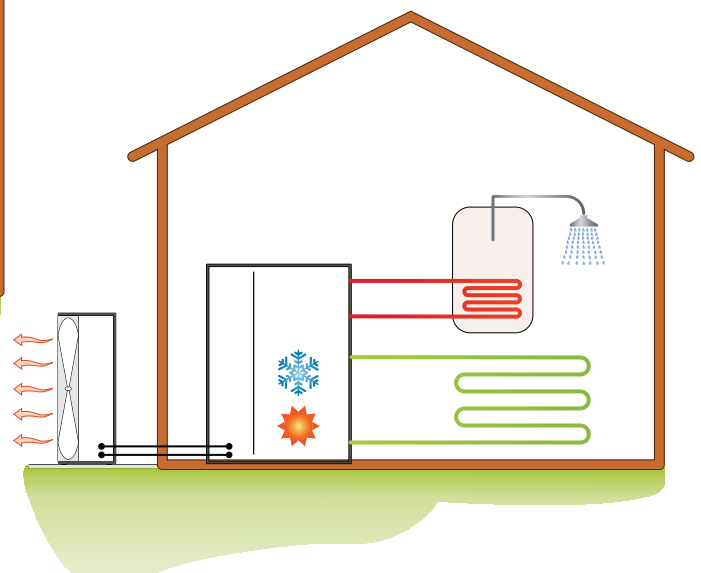

WZT/SW6 4 PIPES VERSION.

WZT - WZT/SW6 Versions	Code	06	08	10M	10T	14M	14T
Main switch		●	●	●	●	●	●
Compressor automatic switch		●	●	●	●	●	●
Flow switch		●	●	●	●	●	●
Evap/condens pressure control by transducer and fan speed control	DCCF	●	●	●	●	●	●
Fresh air temperature probe for set-point compensation		●	●	●	●	●	●
Specific software for operation priorities		●	●	●	●	●	●
Remote ON/OFF digital input		●	●	●	●	●	●
Summer/Winter digital input		●	●	●	●	●	●
LS Low noise version (internal section)	LS00	●	●	●	●	●	●
Condensate tray with anti-freeze heater (outdoor section)	BRCA	●	●	●	●	●	●
Rubber anti-vibration mountings	KAVG	○	○	○	○	○	○
Evaporator antifreeze heater (basic version only)	RAEV	○	○	○	○	○	○
Refrigerant circuit pressure gauges	MAML	○	○	○	○	○	○
Electronic soft starter	DSSE	○	○	○	○	●	○
Remote control panel	PCRL	○	○	○	○	○	○
Serial interface card RS485	INSE	○	○	○	○	○	○
Electronic thermostatic valve	VTEE	○	○	○	○	○	○
High efficiency E.C. fans	VECE	○	○	○	○	○	○

● Standard, ○ Optional, – Not Available.

### INDOOR UNITS

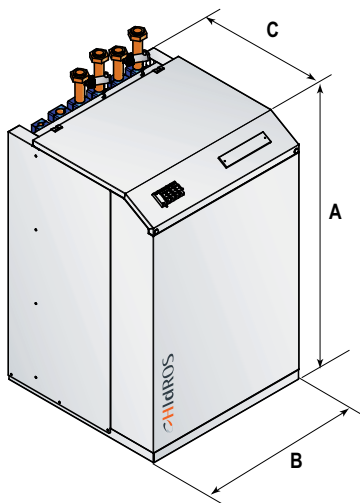

WZT 06 ÷ 21

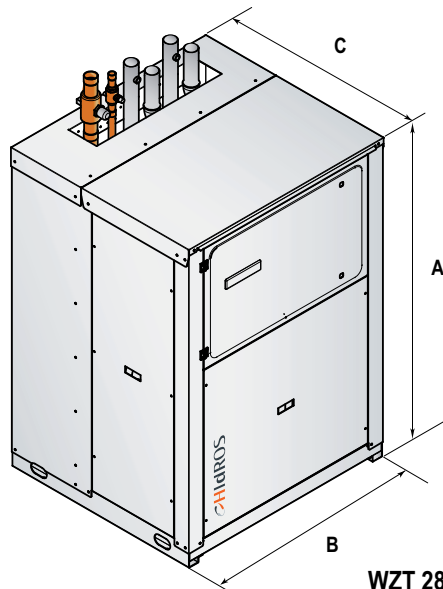

WZT 28 ÷ 92

Mod.	A (mm)	B (mm)	C (mm)	Kg
06	900	600	600	100
08	900	600	600	105
10M	900	600	600	110
10T	900	600	600	110
14M	1255	600	600	130
14T	1255	600	600	130
21	1255	600	600	150
28	1270	850	765	165
42	1270	850	765	165
52	1566	1101	1005	460
72	1566	1101	1005	480
82	1566	1101	1005	490
92	1566	1101	1005	580

WZT - WZT/SW6 Versions	Code	21	28	42	52	72	82	92
Main switch		●	●	●	●	●	●	●
Compressor automatic switch		●	●	●	●	●	●	●
Flow switch		●	●	●	●	●	●	●
Evap/cond pressure control by transducer and fan speed control	DCCF	●	●	●	●	●	●	●
Fresh air temperature probe for set-point compensation		●	●	●	●	●	●	●
Specific software for operation priorities		●	●	●	●	●	●	●
Remote ON/OFF digital input		●	●	●	●	●	●	●
Summer/Winter digital input		●	●	●	●	●	●	●
LS Low noise version (internal section)	LS00	●	●	●	●	●	●	●
Condensate tray with anti-freeze heater (outdoor section)	BRCA	●	●	●	●	●	●	●
Rubber anti-vibration mountings	KAVG	○	○	○	○	○	○	○
Evaporator antifreeze heater (basic version only)	RAEV	○	○	○	○	○	○	○
Refrigerant circuit pressure gauges	MAML	○	○	○	○	○	○	○
Electronic soft starter	DSSE	○	○	○	○	○	○	○
Remote control panel	PCRL	○	○	○	○	○	○	○
Serial interface card RS485	INSE	○	○	○	○	○	○	○
Electronic thermostatic valve	VTEE	○	○	○	○	○	○	○
High efficiency E.C. fans	VECE	○	○	○	○	○	○	○

● Standard, ○ Optional, – Not Available.

## OUTDOOR UNITS

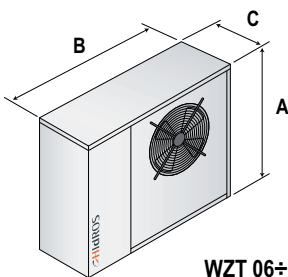

WZT 06÷10

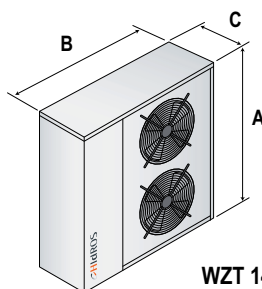

WZT 14÷21

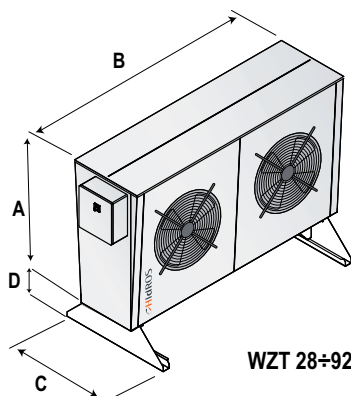

WZT 28÷92

Mod.	A (mm)	B (mm)	C (mm)	D (mm)	Kg
06	989	1160	380	-	47
08	989	1160	380	-	47
10M	989	1160	380	-	50
10T	989	1160	380	-	50
14M	1323	1245	423	-	56
14T	1323	1245	423	-	56
21	1424	1510	473	-	91
28	1035	3065	850	350	112
42	1035	3065	850	350	112
52	1615	2900	1200	350	230
72	1615	4110	1200	350	378
82	1615	4110	1200	350	470
92	1615	5300	1200	350	517